

CABLE WINE SYSTEMS® Installation & Assembly Manual

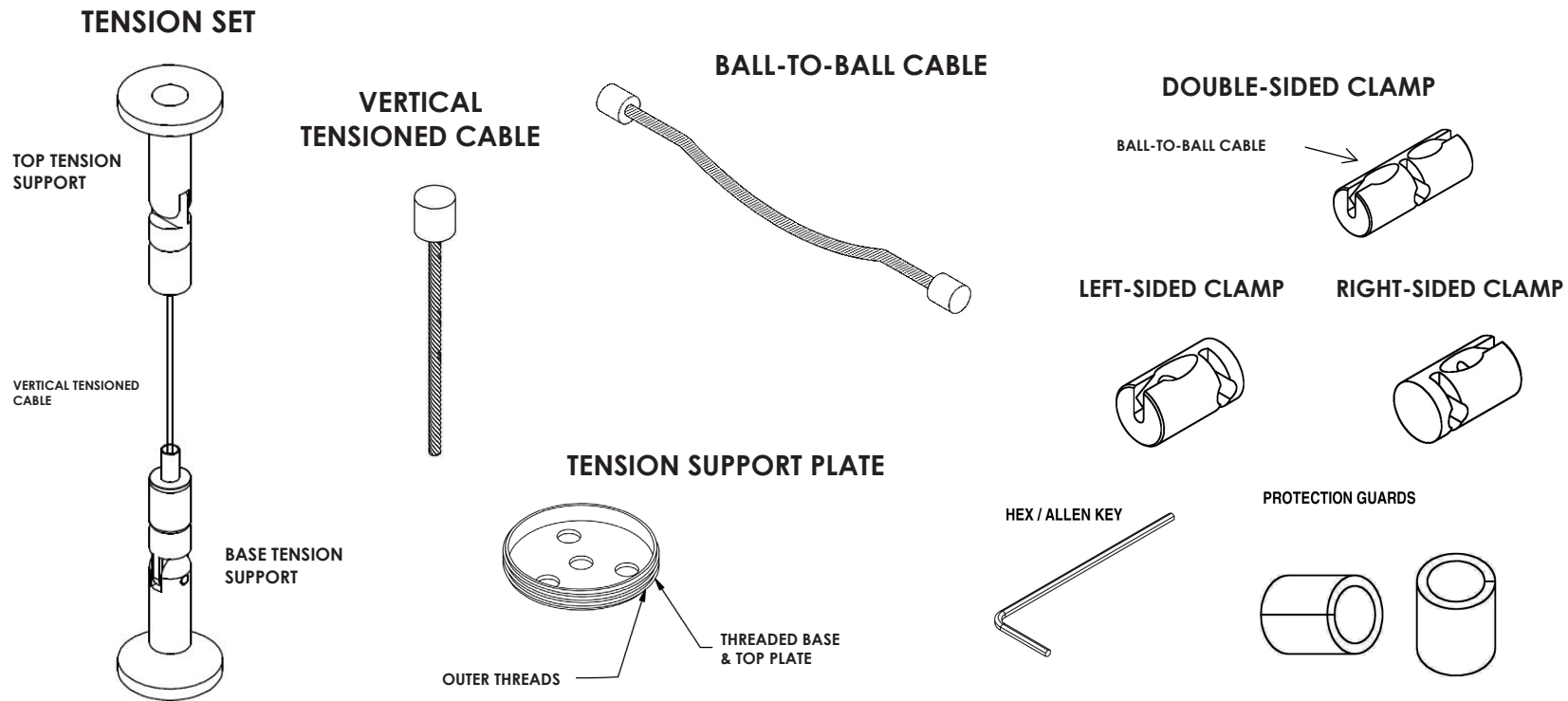

CABLE WINE SYSTEMS® Parts & Pieces



Items & Tools Required for Proper Installation of the CABLE WINE SYSTEMS®

- ✓ measuring tape
- ✓ masking or painters tape
- ✓ drill with #8 screw bit
- ✓ 2 inch #8 screws or equivalent (6 per tension set)
- ✓ 1/8 inch diameter wood drill bit
- ✓ 2 channel lock pliers
- ✓ cable cutters
- ✓ laser that provides horizontal, vertical, and plumb
- ✓ plumb line (if laser does not provide plumb option)
- ✓ black marker and pencil
- ✓ allen/hex keys (provided)
- ✓ large 24 inch square
- ✓ tightening protection guards (provided)
- ✓ stepladder

CABLE WINE SYSTEMS

ASSEMBLY MANUAL:
NECK OUT

WARNING
The installation and assembly instructions described in this manual are based on typical room construction using 2" x 8" ceiling joists (or greater) with a ceiling height of up to 10'.

Installation adjustments may be required for any rooms or locations that do not fall within these standard parameters. CABLE WINE SYSTEMS Inc. is not responsible for any damage, loss and/or injuries that may result from improper installation or assembly of the CABLE WINE SYSTEMS® or its parts.

ATTENTION: READ CAREFULLY BEFORE INSTALLING, ASSEMBLING OR USING THE CABLE WINE SYSTEM®

WARNING

These instructions and safety information should be reviewed by all consumers and installers of CABLE WINE SYSTEMS® products, and must be preserved and provided to any subsequent user or purchaser of the system or its parts.

1. Install all CABLE WINE SYSTEMS® parts according to the installation instructions contained in this manual and use components only as directed. Failure to install the CABLE WINE SYSTEM correctly may result in ceiling deformities (e.g. bowing, rippling) or loose cables or connections. If any such issues occur or are observed, remove all wine bottles from the system immediately and contact a CABLE WINE SYSTEMS® representative.
2. CABLE WINE SYSTEMS® wine racking should only be installed or rearranged by trained professionals who have read and understand these instructions and warnings. Do-It-Yourselfers should NEVER attempt to install CABLE WINE SYSTEMS® products. A qualified professional contractor should always be involved in job-site inspection, product selection, assembly and installation of the CABLE WINE SYSTEM.
3. Local codes and regulations concerning building, fire, sanitation, or seismic requirements may apply to some installations of the CABLE WINE SYSTEMS®. It is the responsibility of the owner or purchaser of the system to check with local building authorities to determine which codes or regulations, if any, apply, and always install the CABLE WINE SYSTEMS® in compliance with all such requirements.
4. Do not combine CABLE WINE SYSTEMS® products with non-CABLE WINE SYSTEMS® products.
5. Never use damaged or defective CABLE WINE SYSTEMS® parts. If any parts are damaged or comprised in any way, DO NOT USE and contact a CABLE WINE SYSTEMS® customer service representative.
6. The CABLE WINE SYSTEM was designed to support the weight of standard wine bottles. Do not exceed allowable load limits for the CABLE WINE SYSTEM. Exceeding allowable loads may compromise the integrity of the CABLE WINE SYSTEM.
7. CABLE WINE SYSTEMS® products are intended for the storage of most standard sized wine bottles (375ml, 750ml, 1.5ml). Use caution when storing anything other than standard wine bottles.
8. To avoid accidental contact with CABLE WINE SYSTEMS® wine racking, never allow any part of the system to protrude into an aisle or doorway.
9. Always provide safe access to all levels of the CABLE WINE SYSTEMS® wine racking in accordance with applicable regulations, building and fire codes. Never allow anyone to climb, walk or stand on CABLE WINE SYSTEMS® wine racking.
10. Never alter, modify or otherwise structurally change any aspects of the CABLE WINE SYSTEMS® wine racking or any of its parts. Modification or alteration may cause the racking system or its parts to become structurally unsafe.
11. CABLE WINE SYSTEMS® is not responsible for improper or unsafe bottle removal practices. Due to the front cradling cables being positioned higher in order to support the neck of the wine bottles, proper bottle retrieval requires that the bottles be lifted above the front cable before being removed from the system.

IMPORTANT: FAILURE TO FOLLOW THESE INSTRUCTIONS AND WARNINGS MAY RESULT IN PERSONAL INJURY, PROPERTY DAMAGE, WINE DAMAGE OR LOSS AND/OR DAMAGE TO THE CABLE WINE SYSTEMS® WINE RACKING SYSTEM ITSELF.

STEP 1: CEILING AND FLOOR REINFORCEMENT

1. Install 2" x 4"s between the floor joists above where the Cable Wine System will be installed (Sketch A). Top Tension Support Plates will be secured through the finished cladding and into a minimum two inches of the 2" x 4"s.
2. To install with a crown, run 2" x 4"s perpendicular to the underside of the floor joists and use 3/4" plywood for the crown.
3. If the existing concrete floor area is covered by tiles, stone or hardwood, use metal screw plugs or anchors to secure the base plates.
4. If you intend to build an elevated base to match the bulkhead above, the use of 2" x 4"s secured with concrete screws with 3/4" plywood may be used. (Sketch B)

STEP 2: SETTING BASE TENSION SUPPORT PLATES

1. To set locations for the Base Tension Support Plates, use a laser level or large square with chalk line.
2. The back row Base Tension Support Plates should be located a minimum 3" away from the wall.
3. Using a laser or chalk line, mark the location of each of the back row Base Tension Support Plates 5" apart from their centers. (Sketch C).
4. Then use laser or large square with chalk line to lay out the front row of Base Tension Support Plates 7 1/2" center to center directly in front of the locations marked for the back Base Tension Support Plates. The locations for the front Tension Support Plates should also be marked on the floor.

STEP 3: SETTING TOP TENSION SUPPORT PLATES

1. Using a laser or plumb line over each of the Base Tension Support Plate locations, mark each of the corresponding Top Tension Support Plate locations on the ceiling directly above each support. Centre each Top Tension Support Plate at its marked location and screw into ceiling using 2" #8 wood screws (or equivalent).
2. After all of the Top Tension Support Plates have been fully secured, center each Base Tension Support Plate over its marked location and secure to the floor using 2" #8 wood screws (or equivalent).

**CABLE WINE
SYSTEMS**

**ASSEMBLY
MANUAL:
NECK OUT**

WARNING

The installation and assembly instructions described in this manual are based on typical room construction using 2" x 8" ceiling joists (or greater) with a ceiling height of up to 10'.

Installation adjustments may be required for any rooms or locations that do not fall within these standard parameters.

CABLE WINE SYSTEMS Inc. is not responsible for any damage, loss and/or injuries that may result from improper installation or assembly of the CABLE WINE SYSTEMS® or its parts.

STEP 4: INSTALLATION OF TENSION SETS TO TOP AND BASE TENSION SUPPORT PLATES

1. Secure the Tension Supports to the Tension Support Plates by turning the mount onto the threaded base completely.
2. Rotate the cap on the Top Tension Support four complete turns, so that the cap is loosened 1/4 inch. Do not completely remove cap. (Sketch F)
4. Gently feed cable through hole in the Base Tension Support until the vertical cable is taught. DO NOT cut the cable at this step. Ensure the cable is set (without using force) to the correct length, as the cable should be set **only once**. (TIP: Cable should be set so that it can move slightly but is not loose or able to sway).
5. To apply proper tension on each cable, rotate the Top Tension Support Cap on to the Top Tension Support. Use two channel pliers WITH RUBBER PROTECTION GUARDS to completely tighten cap (See picture #1)
6. Cut the remaining cable from the base tension set, so that no cable is left showing at the base (Sketch H).
7. Repeat the same process for every tension set.
8. Note, a slight bowing of the vertical cables towards the center of the system naturally occurs when the bottles are placed on to the system.

Step 5: Installation of Clamps and Ball-to-Ball Cables (Sketch I)

1. See addendum to this manual for instruction on stringing together the horizontal cables.
2. Position laser for BACK ROW MARKINGS FIRST. Set the initial horizontal line 5" above the finished floor and mark each back row location on the cables with a black marker. Set and mark all subsequent back row clamp locations at minimum 4 1/2" intervals center to center.
2. Front row cable clamps should be set 1" higher than their back row counterparts (due to the fact that the front row cables will support the necks of the wine bottles while the back cables will support the bottoms). As a result, the first row horizontal line should be set and marked 6" above the finished floor with all subsequent lines being marked at intervals equivalent to the spacing that was used for the back row (minimum 4 1/2") measuring center to center.
3. Install left, double and right sided clamps at marked locations on all tensioned vertical cables ensuring that ball drop slots are always facing up. Secure each clamp firmly from behind using the hex/allen keys provided.
4. Every cable should be tested after it is installed using upward pressure to make sure that it has been securely locked into place.



**CABLE WINE
SYSTEMS**

**ASSEMBLY
MANUAL:
NECK OUT**

WARNING

The installation and assembly instructions described in this manual are based on typical room construction using 2" x 8" ceiling joists (or greater) with a ceiling height of up to 10'.

Installation adjustments may be required for any rooms or locations that do not fall within these standard parameters.

CABLE WINE SYSTEMS Inc. is not responsible for any damage, loss and/or injuries that may result from improper installation or assembly of the CABLE WINE SYSTEMS® or its parts.

Installation Sketches (Neck Out)

SKETCH A: Ceiling Reinforcement

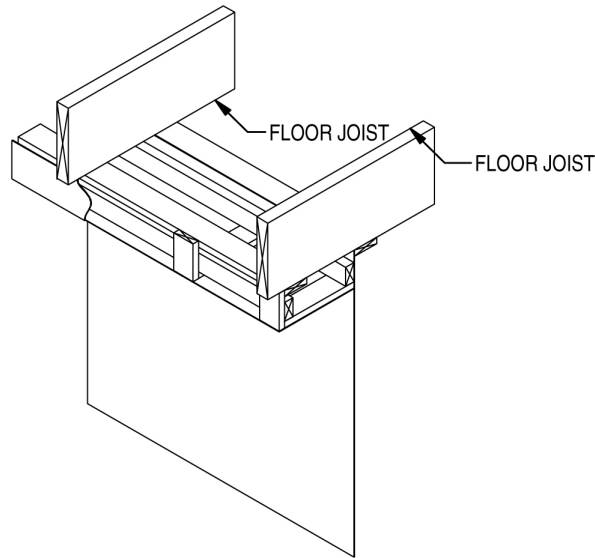

SKETCH B: Elevated Base

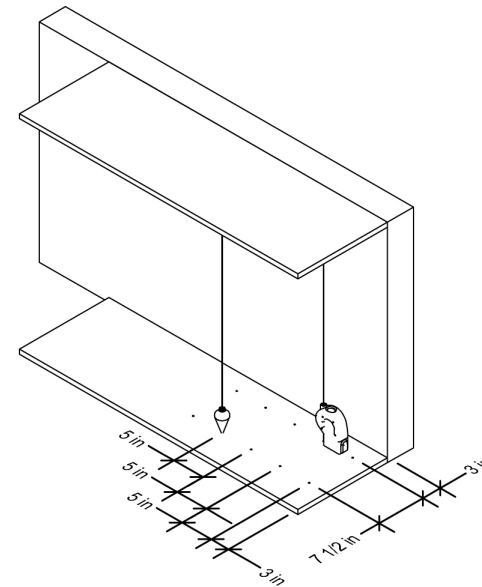
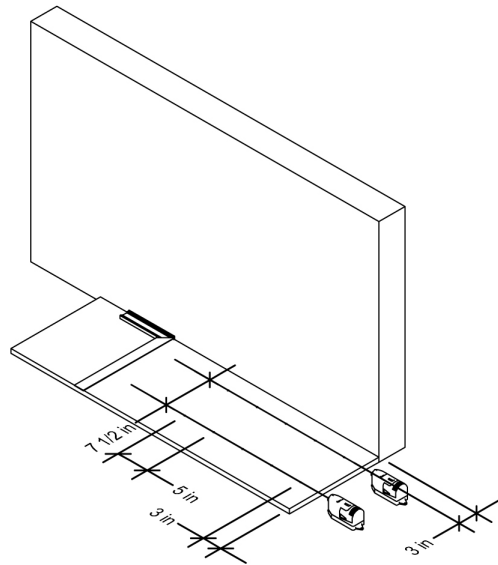
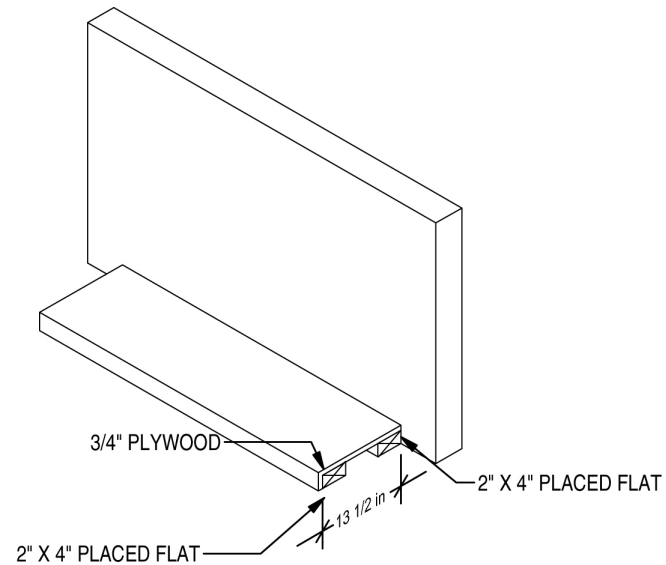

SKETCH C: Setting Base Tension Support Plates

SKETCH D: Setting Top Tension Support Plates

CABLE WINE SYSTEMS

**ASSEMBLY MANUAL:
NECK OUT**

WARNING
The installation and assembly instructions described in this manual are based on typical room construction using 2" x 8" ceiling joists (or greater) with a ceiling height of up to 10'. Installation adjustments may be required for any rooms or locations that do not fall within these standard parameters. CABLE WINE SYSTEMS Inc. is not responsible for any damage, loss and/or injuries that may result from improper installation or assembly of the CABLE WINE SYSTEMS® or its parts.

Installation Sketches

Sketch F:

Turning Only Halfway on Threads

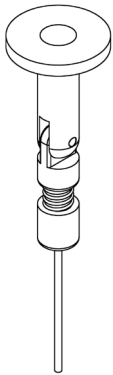

Sketch G:

Gently Feed Cable Through Base Tension Set

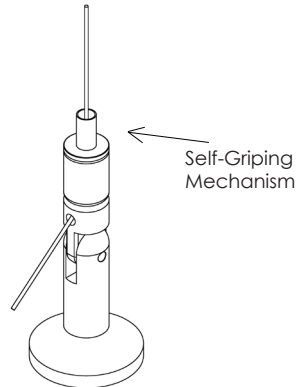

Sketch I: Installation of Clamps and Ball-to-Ball Cables

- 1-T: Top Tension Supports
- 1-B: Base Tension Supports
- 2: Left-Sided Clamps
- 3: Right-Sided Clamps
- 4: Double-Sided Clamps
- 5: Vertical Tensioned Cables
- 6: Ball-to-Ball Cables

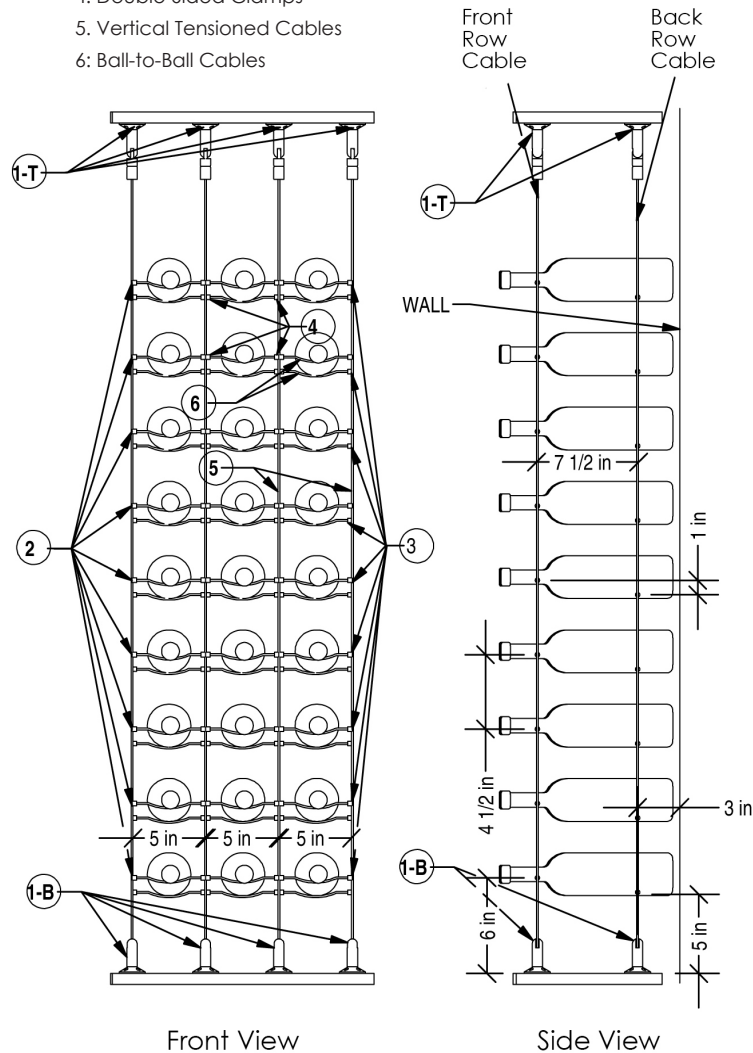

Sketch H:

Cable Cutting

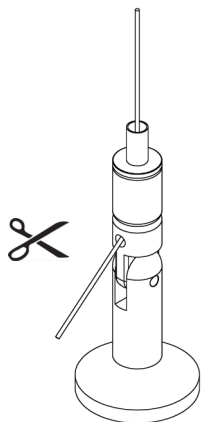

Picture #1:

Tightening Top Tension Support Cap Utilizing Protection Guards and Pliers



WARNING

The installation and assembly instructions described in this manual are based on typical room construction using 2" x 8" ceiling joists (or greater) with a ceiling height of up to 10'.

Installation adjustments may be required for any rooms or locations that do not fall within these standard parameters.

CABLE WINE SYSTEMS Inc. is not responsible for any damage, loss and/or injuries that may result from improper installation or assembly of the CABLE WINE SYSTEMS® or its parts.

CABLE WINE SYSTEMS® Installation & Assembly Manual

Stringing Together the Clamps and Cables

Left-Sided Clamps



Ball-to-Ball Cable Slot



Smooth Face

Right-Sided Clamps



Ball-to-Ball Cable Slot



Smooth Face



STEP 1: Loosen the Screw to Open the Ball Cable Slot on the Clamp.

Using the allen key provided, loosen the screw located on the opposing side of the ball-to-ball cable slot. Start with an end clamp (left-sided or right-sided clamp).

TIP: The screw does not need to be removed entirely.



Ball-to-Ball Cable Tightening Screw

Allen Key

STEP 2: Attach a Ball-to-Ball Cable to the Loosened Side Clamp

Place the ball-to-ball cable securely in the loosened ball-to-ball cable slot and tighten the screw using the allen key until the cable is held firmly in place.

TIP: Using a non-slip surface, such as a rubber mat, during the stringing process will help to prevent the cables from twisting.



Ball-to-Ball Cable in Slot

Ball-to-Ball Cable

Double-Sided Clamps



Ball-to-Ball Cable Slots



Smooth Face



Ball-to-Ball Cable Tightening Screws

STEP 3: Attach Ball-to-Ball Cables to the Double-Sided Clamps

Using the same procedures as above, secure a ball-to-ball cable in each ball slot of the double-sided clamps.



Double-Sided Clamp with a Connected Ball-to-Ball Cable



Ball-to-Ball Cable

CABLE WINE SYSTEMS

ASSEMBLY MANUAL

WARNING

The installation and assembly instructions described in this manual are based on typical room construction using 2" x 8" ceiling joists (or greater) with a ceiling height of up to 10'. Installation adjustments may be required for any rooms or locations that do not fall within these standard parameters. CABLE WINE SYSTEMS Inc. is not responsible for any damage, loss and/or injuries that may result from improper installation or assembly of the CABLE WINE SYSTEMS® or its parts.

Addendum
Page 1 of 2

CABLE WINE SYSTEMS® Installation & Assembly Manual

Stringing Together the Clamps and Cables

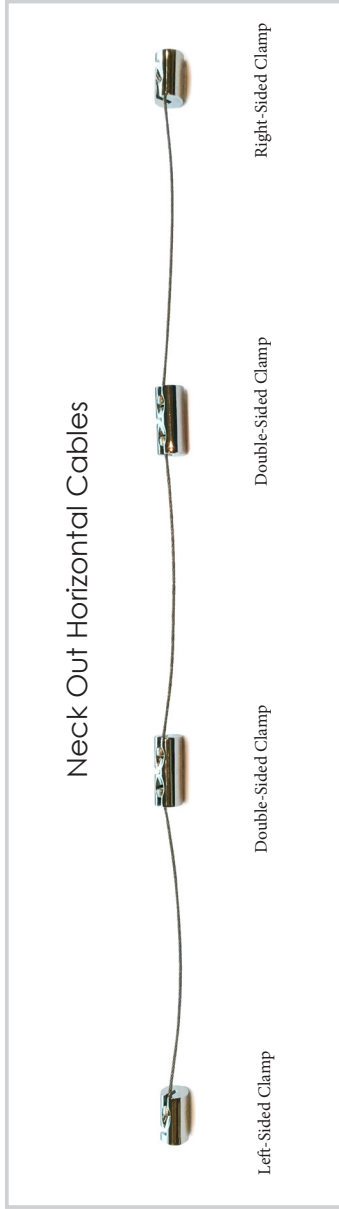

STEP 4A: For NECK OUT Configuration Horizontal Cables

String together enough ball-to-ball cables and clamps to match the number of columns in your design. You must create two strings for each horizontal row. One to support the neck of the bottles and the other to support the base of the bottles.

The above image is of one horizontal string showing a system with three columns. Refer to your design and put together all of the horizontal strings before installing them on the vertical tensioned cables.

TIP: Ensure that the smooth sides of each clamp are facing the same direction and that the clamps and cables do not twist during the stringing process.

STEP 4B: For LABEL VIEW Configuration Single-Depth Column

For single-depth label view columns, connect one ball-to-ball cable between a left-sided and right-sided clamp. Two of these is required for each bottle (one to support the neck of the bottle and the other to support the base of the bottle).

Label View Single-Depth Cable



STEP 4C: For LABEL VIEW Configuration Double-Depth Column

For double-depth columns you must create double bottle strings by connecting two ball-to-ball cables together for each horizontal row. Again, remember that a duplicate set must be made of each string to support both the neck of the bottle and the base of each bottle.

Label View Double-Depth Cables



Step 5: Attaching the Horizontal Rows to the Vertical Tensioned Cables

Remove the set screw from the tension cable slot on the clamp. Place the clamp on the vertical tensioned cable with the smooth side visible. Then replace and tighten the set screw to secure the clamp to the cable.

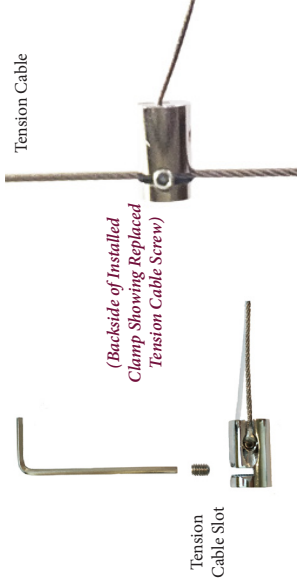

TIP: Refer to Sketch 1 in the installation manual for standard spacing of horizontal rows.

WARNING

The installation and assembly instructions described in this manual are based on typical room construction using 2" x 8" ceiling joists (or greater) with a ceiling height of up to 10'. Installation adjustments may be required for any rooms or locations that do not fall within these standard parameters. CABLE WINE SYSTEMS Inc. is not responsible for any damage, loss and/or injuries that may result from improper installation or assembly of the CABLE WINE SYSTEMS® or its parts.